

WAAS CH 97439 W27A	APP CRS 273°	Rwy Idg TDZE 879 Apt Elev 884
--	------------------------	---

RNAV (GPS) RWY 27

NEWARK-HEATH (VTA)

<p>⚠ Circling Rwy 9 NA at night. Rwy 27 helicopter visibility reduction below ¼ SM NA. DME/DME RNP-0.3 NA.</p>			<p>MISSED APPROACH: Climb to 2000 then climbing right turn to 3000 direct APE VORTAC and hold.</p>	
ASOS 121.125	COLUMBUS APP CON 125.95 317.775	CLNC DEL 125.175	UNICOM 122.7 (CTAF)	123.3 0

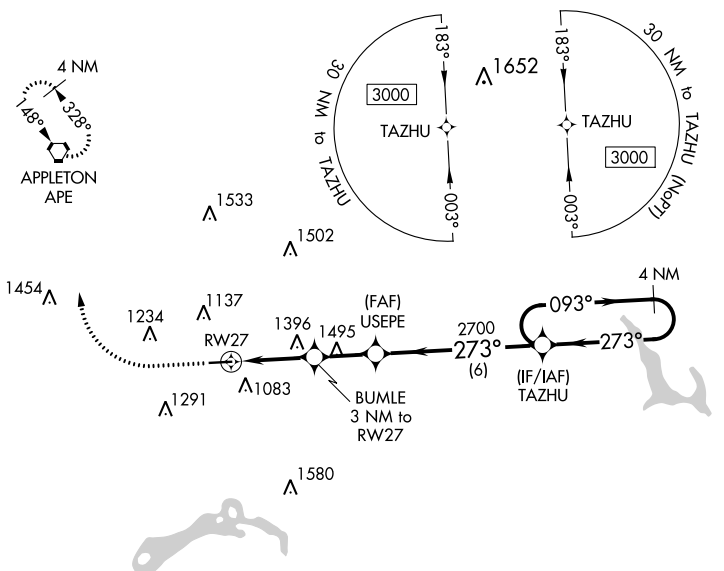

ELEV 884	TDZE 879
-----------------	-----------------

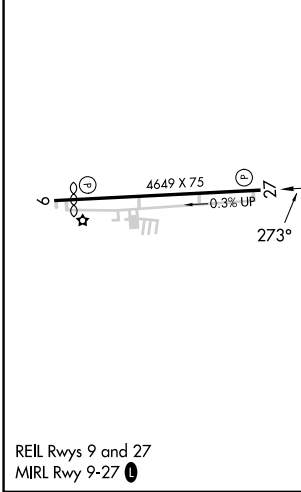

2000	3000	APE	VGSI and descent angles not coincident (VGSI Angle 3.25/TCH 20).	4 NM Holding Pattern
		USEPE	TAZHU	3000
CATEGORY	A	B	C	D
LP MDA	1680-1 801 (800-1)	1680-1¼ 801 (800-1¼)	1680-2½ 801 (800-2½)	801 (800-2½)
LNAV MDA	1700-1 821 (900-1)	1700-1¼ 821 (900-1¼)	1700-2½ 821 (900-2½)	821 (900-2½)
C CIRCLING	1700-1¼	816 (900-1¼)	1760-2½ 876 (900-2½)	1760-2¾ 876 (900-2¾)

EC-2, 03 OCT 2024 to 31 OCT 2024

EC-2, 03 OCT 2024 to 31 OCT 2024