

|  |                        |                             |                                      |
|--|------------------------|-----------------------------|--------------------------------------|
| WAAS<br>CH <b>48902</b><br><b>W10A</b> | APP CRS<br><b>096°</b> | Rwy Idg<br>TDZE<br>Apt Elev | <b>8424</b><br><b>7</b><br><b>65</b> |
|--|------------------------|-----------------------------|--------------------------------------|

# RNAV (GPS) Z RWY 10L

FORT LAUDERDALE/HOLLYWOOD INTL (FLL)

RNP APCH-GPS.

**⚠** For uncompensated Baro-VNAV systems, LNAV/VNAV NA below 7°C or above 54°C. Inop table does not apply to LPV all Cats. LNAV procedure NA during simultaneous operations. For inop ALS, increase LNAV/VNAV visibility all Cats to 1½ SM, LNAV visibility Cat A and B to RVR 5500 and Cats C/D to RVR 6000. Use of FD or AP required during simultaneous operations. Simultaneous approach authorized.

**MALSR**



**MISSED APPROACH:** Climb to 800 then climbing left turn to 4000 direct MARTS and hold. Continue climb-in-hold to 4000.

|                        |                                       |  |                         |                          |       |
|------------------------|---------------------------------------|--|-------------------------|--------------------------|-------|
| D-ATIS<br><b>135.0</b> | MIAMI APP CON<br><b>133.775 285.6</b> | <b>FORT LAUDERDALE TOWER</b><br><b>119.3 257.8</b> | GND CON<br><b>121.4</b> | CLNC DEL<br><b>128.4</b> | CPDLC |
|------------------------|---------------------------------------|--|-------------------------|--------------------------|-------|

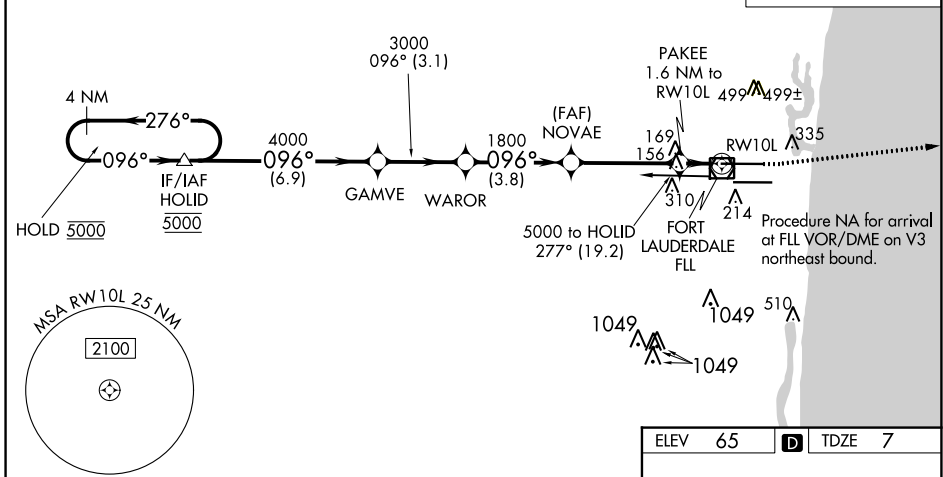
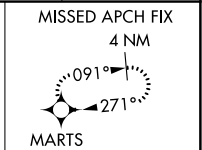

|         |          |        |
|---------|----------|--------|
| ELEV 65 | <b>D</b> | TDZE 7 |
|---------|----------|--------|

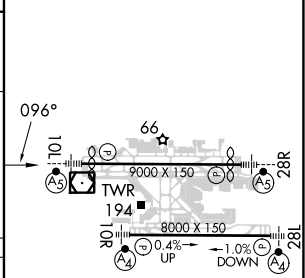
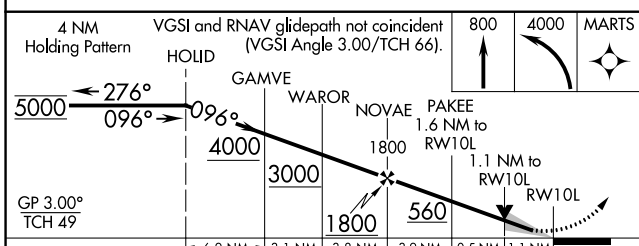

| CATEGORY          | A      | B           | C                    | D                      |
|-------------------|--------|-------------|----------------------|------------------------|
| LPV DA            | 207/24 |             | 200 (200-½)          |                        |
| LNAV/VNAV DA      | 495/50 |             | 488 (500-1)          |                        |
| LNAV MDA          | 420/24 | 413 (400-½) | 420/40               | 413 (400-¾)            |
| <b>C</b> CIRCLING | 680-1  | 615 (700-1) | 800-2<br>735 (800-2) | 800-2¼<br>735 (800-2¼) |

HIRL Rwy 10L-28R and 10R-28L

SE-3, 31 OCT 2024 to 28 NOV 2024

SE-3, 31 OCT 2024 to 28 NOV 2024