

WAAS CH 65733 W27A	APP CRS 267°	Rwy ldg 6302 TDZE 899 Apt Elev 901
--	------------------------	---

RNAV (GPS) RWY 27

HECTOR INTL (F.A.R.)

RNP APCH.	MISSED APPROACH: Climb to 3500 direct IDVIY and hold.
Baro-VNAV NA. Rwy 27 helicopter visibility reduction below 3/4 SM NA.	

ATIS 124.5 379.2	FARGO APP CON 120.4 377.15	FARGO TOWER 133.8 290.4	GND CON 121.9 348.6	CLNC DEL 121.9 348.6
----------------------------	--------------------------------------	-----------------------------------	-------------------------------	--------------------------------

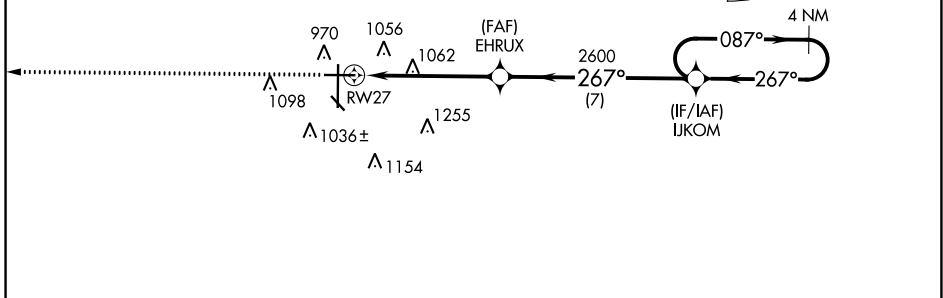
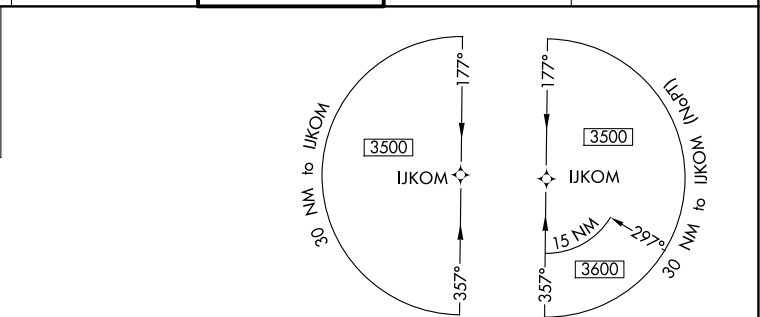
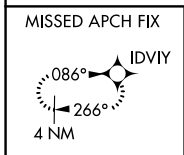

ELEV 901	D	TDZE 899
----------	----------	----------

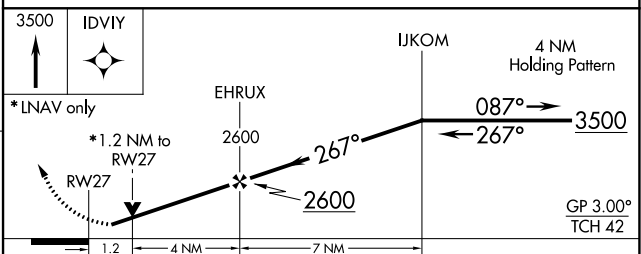
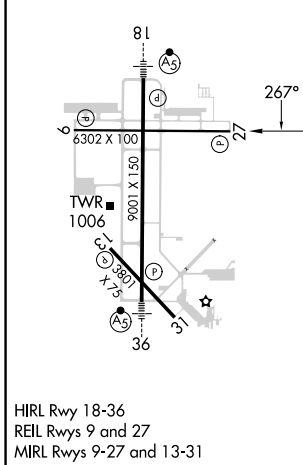

CATEGORY	A	B	C	D
LPV DA		1149-3/4	250 (300-3/4)	
LNAV/VNAV DA		1231-1/8	332 (400-1/8)	
LNAV MDA	1320-1	421 (500-1)	1320-1/4	421 (500-1/4)
CIRCLING	1380-1	479 (500-1)	1520-1/4	1620-2/4
			619 (700-1/4)	719 (800-2/4)